

## Airport Trailers

FOR DANGEROUS / VALUABLE GOODS



# Airport Trailer for Dangerous / Valuable Goods

Technical specifications	KGT1000-01
Loading capacity [kg]	1000
Trailer self-weight [kg]	435
Max. towing speed [km/h]	40
Wheels	4,00-8 Solid
A - Overall length [mm]	3484
B - Overall length with drawbar in vertical position [mm]	2630
C - Loading platform length [mm]	2022
D - Loading platform width [mm]	1205
E - Overall height [mm]	1498
F - Loading platform height above ground [mm]	522
G - Rear coupling height [mm]	265
H - Wheel base [mm]	1200
J - Towing eyelet diameter [mm]	42,5

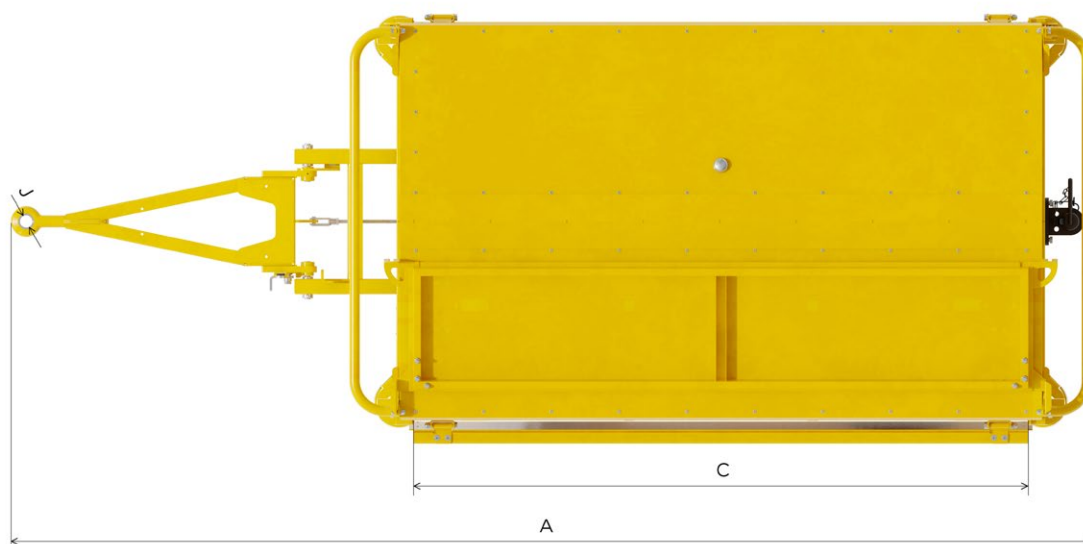
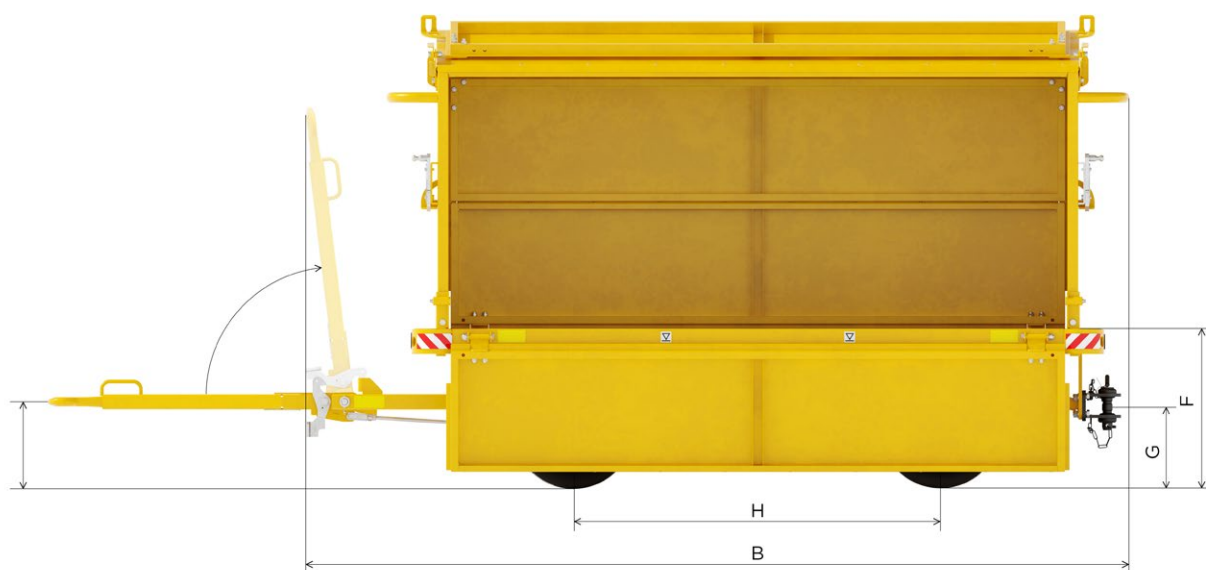
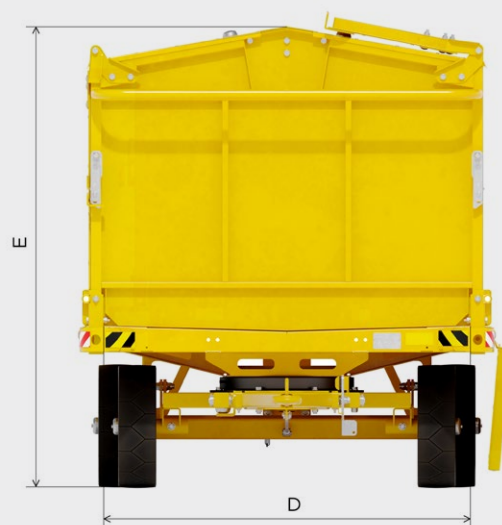

## KEY FEATURES

- Specifically designed for handling of dangerous or valuable goods
- Durable, fully-enclosed high-grade steel construction
- With components from renowned manufacturers (Jost, Continental, Rockinger...)
- Lockable solid covering
- Weatherproof design
- Integrated cargo tie down points
- Loading platform with anti-slip mat
- Comfortable handling with automatic sidewall latching
- Easily replaceable parts
- Low maintenance costs & long operation life
- Hitching of up to 7 trailers together
- Front wheel parking brake - activated by raising the drawbar to vertical position
- Foot-operated towbar latch release
- Durable 3-layer powder coated surface

## CUSTOMIZATIONS & OPTIONS

- Alternative towing eyelets and rear couplings
- Parking brake activation also by lowering the drawbar
- Surface finish in any RAL colour
- Hot-dip galvanized surface treatment
- Forklift pockets
- Other modifications upon consultation

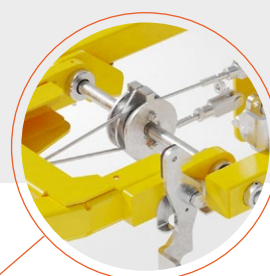

OPTION  
Up & down brake activation



Automatic sidewall latching

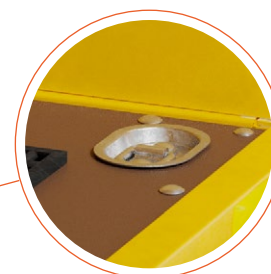

Four cargo tie-down points

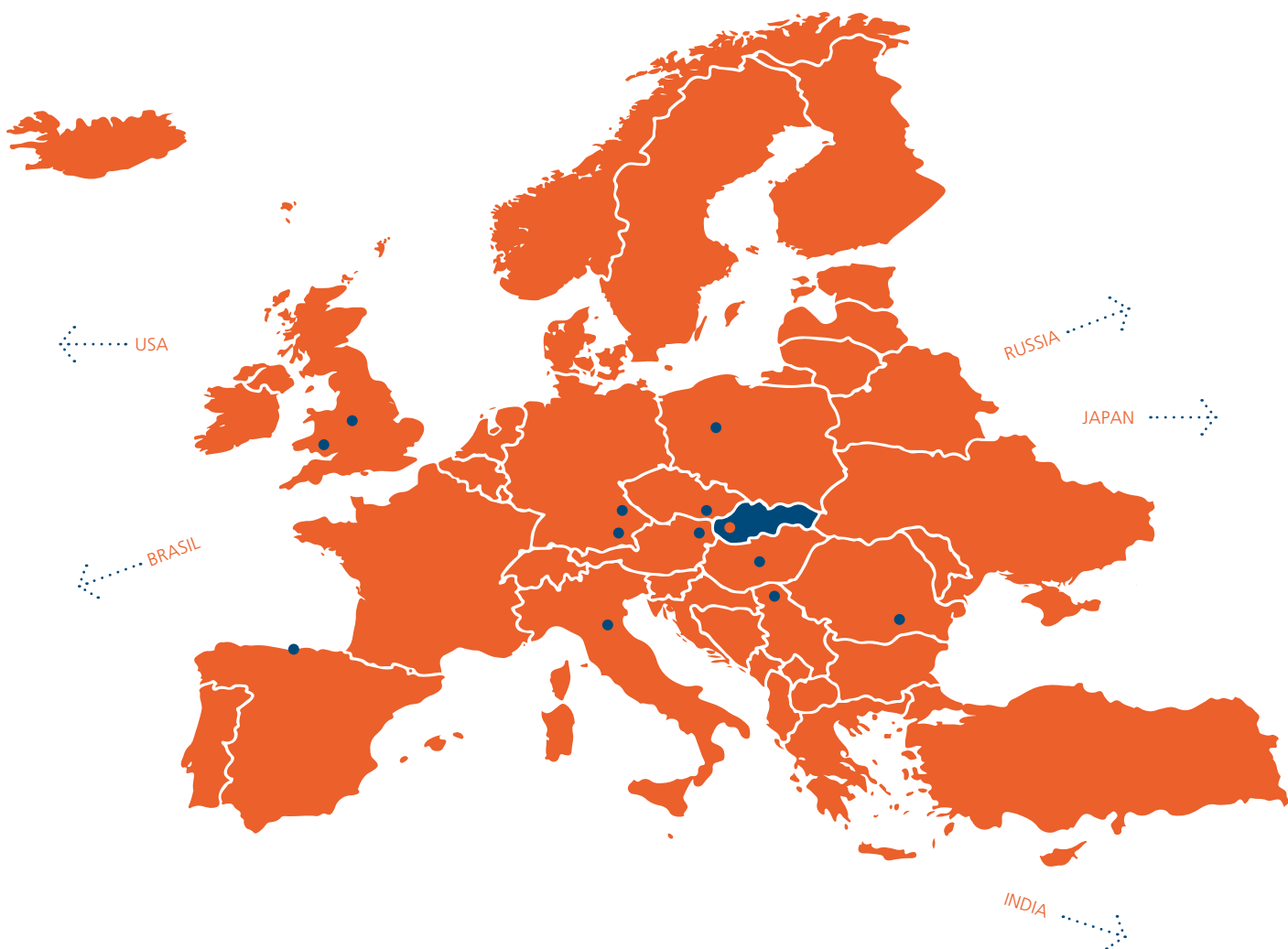

## KNOTT SLOVAKIA

### YOUR TAILOR-MADE MANUFACTURER

As a strategic member of the KNOTT Group we develop and produce key products in trailer technology. We are also involved in the production of sophisticated industrial brakes and have evolved into a high-quality airport ground support equipment manufacturer as well.

The ability to tailor our products to customer's needs, along with professional consulting and cooperation since the early development stages of a new product, as well as the in-house accredited testing laboratory are the main advantages of our company.

Paying attention to customer feedback, combining newest technologies with know-how based on decades-long experiences, and the implied highest product quality are characteristic for all companies within the Knott Group.

#### KNOTT spol. s r.o.

Dolná 142  
900 01 Modra  
Slovak Republic

tel.: +421 33 690 2511

e-mail: [gse@knott.sk](mailto:gse@knott.sk)

[www.knott.sk](http://www.knott.sk)



# KNOTT)))

